

Email: info@DSPManufacturing.com
1921 S. Quaker Ridge Place
Ontario, CA 91761
Ph: 1.877.DSPM POWER
1.877.377.6769
Fax: 909.930.3335

COBRA MICRO

STAND-BY EMERGENCY LIGHTING INVERTER

Keep the lights "ON" when you need them the most.

Single Phase 75 W - 450 W

Made In The USA 

Defends your environment against unwanted power outage and electrical disturbances by providing:

- DSPM Watchdog software always on guard.
- Dependable DSP/PWM technology for unsurpassed reliability.
- Economical for the lowest overall cost for your light safety, with an Energy Star Rating.
- Temperature compensating technology that controls batteries for the longest battery life.
- Sealed maintenance free batteries.
- Full light output for entire 90 minutes.
- Self-diagnostics for a safe and secure lighted environment.
- Pure sine wave output for all types of lamps.
- ECM module is a patented technology used by DSPM.
- Backup solutions for multiple applications such as: indoor and outdoor emergency lighting, exits, cash registers, computers, strategic electronics and more!
- 10 Year pro-rated battery warranty.
- 5 Year power train warranty.
- Meets federal, state and local codes: UL924, NFPA 101, NFPA 70, NEC and OSHA.
- Cities of Chicago and New York Approved.
- Environmentally Friendly.
- Complies with the Buy American Act.

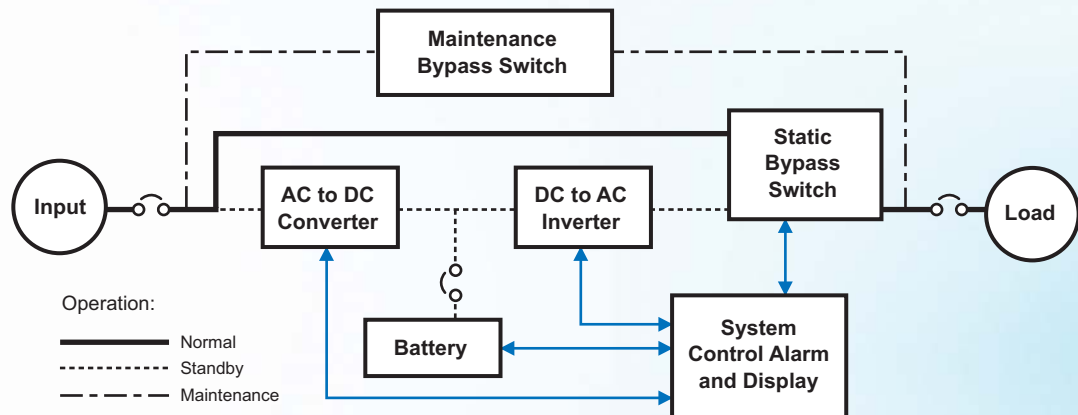

Email: info@DSPManufacturing.com
 1921 S. Quaker Ridge Place
 Ontario, CA 91761
 Ph: 1.877.DSPM POWER
 1.877.377.6769
 Fax: 909.930.3335

COBRA MICRO



- *Standard Power Levels.....75, 100, 125, 200, 300, 350, 400 and 450 Watts
- *Input Voltage120, 277 or 480 VAC
- *Input Voltage Range.....+10%. -15%
- *Output Voltage.....120, 277 or 480 VAC
- *Output Voltage Regulation.....±5% for all loads and battery discharge mode
- *Output Frequency Range.....60 Hz, ±1%
- Crest Factor.....2.5:1 typical
- Input Protection.....Input Main Circuit Breaker
- Output Protection.....Output Main Circuit Breaker
- Surge Protection.....The unit will protect itself and the load against surges as defined in ANSI/IEEE C62.45 category A and B
- Battery.....Sealed maintenance-free (AGM) lead calcium
- Recharge Current.....Conforms to UL924 standards
- External Battery.....Provision for hardware connection of external battery cabinets or DC source
- Efficiency.....≥99% at 100% linear load
- Audible Noise.....<45dB measured on Response Curve "A"
- Safety Agencies.....Listed to UL standard 924
- Operating Temperature.....0° to 40°C (32° to 104°F)
- Storage Temperature.....-20° to 60°C (-4° to 140°F)
- Humidity.....5 - 95%, Non-condensing
- Monitoring.....LED Displays Alarms and Diagnostics
- Transfer Time.....16msec - 60msec

*Consult factory for others.
 Specifications subject to change without notice.



Micro Series	Power Rating	UPS			Weight (lbs)
		W	H	D	
CMIC (Consult factory for others)	VA/W				
	75	17.5"	22.5"	8"	45
	100	17.5"	22.5"	8"	48
	125	17.5"	22.5"	8"	48
	200	17.5"	22.5"	8"	54
	300	17.5"	22.5"	8"	66
	350	17.5"	22.5"	8"	78
	400	17.5"	22.5"	8"	82
450	17.5"	22.5"	8"	86	

Options:

- ECM - Environmental Control Module
- NOF120 - Normally OFF Circuit 120VAC
- NOF227 - Normally OFF Circuit 277VAC
- STUM - Onsite Startup
- EW - Extended Warranty
- FT - Fast Transfer

Represented by: