

Email: info@DSPManufacturing.com  
1921 S. Quaker Ridge Place  
Ontario, CA 91761  
Ph: 1.877.DSPM POWER  
1.877.377.6769  
Fax: 909.930.3335

# DEFENDER MINI



**ONLINE EMERGENCY LIGHTING INVERTER**  
Keep the lights "ON" when you need them the most.

**Single Phase 350 W - 2000 W**

Made In The USA 

*Defends your environment against unwanted power outage and electrical disturbances by providing:*

- DSPM Watchdog software always on guard.
- Display monitor keeps you in control 24/7.
- Dependable DSP/PWM technology for unsurpassed reliability.
- Economical for the lowest overall cost for your light safety, with an Energy Star Rating.
- Temperature compensating technology that controls batteries for the longest battery life.
- Sealed maintenance free batteries.
- Full light output for entire 90 minutes.
- Self-diagnostics for a safe and secure lighted environment.
- Pure sine wave output for all types of lamps.
- ECM module is a patented technology used by DSPM.
- Backup solutions for multiple applications such as: indoor and outdoor emergency lighting, exits, cash registers, computers, strategic electronics and more!
- 10 Year pro-rated battery warranty.
- 5 Year power train warranty.
- Meets federal, state and local codes: UL924, NFPA 101, NFPA 70, NEC and OSHA.
- Cities of Chicago and New York Approved.
- Complies with the Buy American Act.

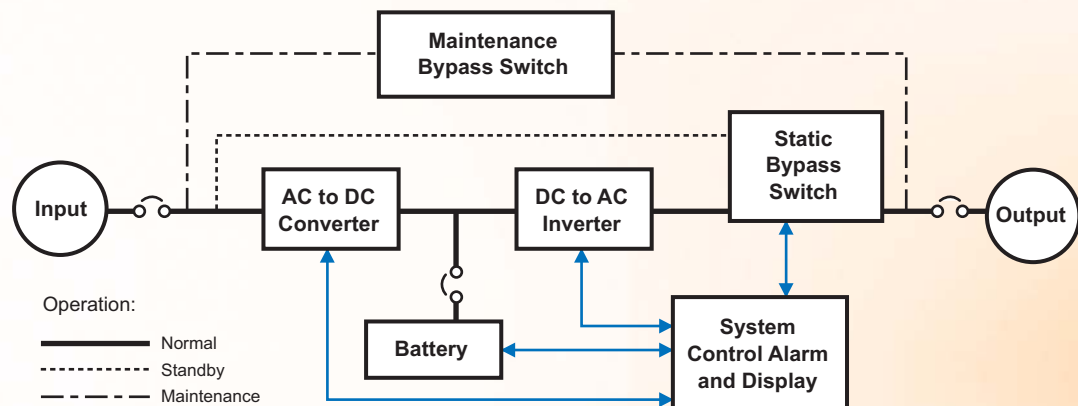

# DEFENDER MINI



Email: info@DSPManufacturing.com  
1921 S. Quaker Ridge Place  
Ontario, CA 91761  
Ph: 1.877.DSPM POWER  
1.877.377.6769  
Fax: 909.930.3335

- \*Standard Power Levels.....350, 525, 700, 750, 875, 1050, 1400 and 2000 Watts
  - \*Input Voltage .....120, 208, 240, 277 or 480 VAC
  - \*Input Voltage Range.....+10%. -15%
  - \*Output Voltage.....120, 208, 277, 480, 120/240 or 120/277 VAC
  - \*Output Voltage Regulation.....±3% for all loads and battery discharge mode
  - \*Output Frequency Range.....60 Hz, ±1%
  - Output Wave Form.....Sine-wave <5% @ 100% linear load
  - Crest Factor.....2.5:1 typical
  - Input Protection.....Input Main Circuit Breaker
  - Output Protection.....Output Main Circuit Breaker
  - Surge Protection.....The unit will protect itself and the load against surges as defined in ANSI/IEEE C62.45 category A and B
  - Battery.....Sealed maintenance-free (AGM) lead calcium
  - Recharge Current.....Conforms to UL924 standards
  - External Battery.....Provision for hardware connection of external battery cabinets or DC source
  - Efficiency.....≥92% at 100% linear load
  - Audible Noise.....<45dB measured on Response Curve "A"
  - Safety Agencies.....Listed to UL standard 924
  - Operating Temperature.....0° to 40°C (32° to 104°F)
  - Storage Temperature.....-20° to 60°C (-4° to 140°F)
  - Humidity.....5 - 95%, Non-condensing
  - Monitoring.....LED Displays Alarms and Diagnostics
- \*Consult factory for others.  
Specifications subject to change without notice.



Mini Series	Power Rating	UPS Cabinet Dimensions			Weight (lbs)
		W	H	D	
DMINI (Consult factory for others)	VA/W				
	350	24"	26"	16"	340
	525	24"	26"	16"	340
	700	24"	26"	16"	370
	750	24"	26"	16"	370
	875	24"	26"	16"	370
	1050	24"	26"	16"	440
	1400	24"	26"	16"	460
2000	24"	26"	16"	600	

**Options:**

- ECM - Environmental Control Module
- NOF120 - Normally OFF Circuit 120VAC
- NOF227 - Normally OFF Circuit 277VAC
- NOH120 - Normally OFF "Hold On" 120VAC
- NOH227 - Normally OFF "Hold On" 277VAC
- OCB - Output Circuit Breaker(s)
- EPO - Emergency Power Off
- RSSP - Remote Indicator Panel
- SNMP - SNMP Card
- FAX - Fax Modem
- FC - Form C Contacts
- SRM - Seismic-Rated Bracket
- WB - Wall Mounted Bracket
- STUM - Onsite Startup
- IDB - Internal Dimmer Bypass
- EMB - External Maintenance Bypass
- EW - Extended Warranty

Represented by: