

Email: info@DSPManufacturing.com
1921 S. Quaker Ridge Place
Ontario, CA 91761
Ph: 1.877.DSPM POWER
1.877.377.6769
Fax: 909.930.3335

DEFENDER PLUS



ONLINE EMERGENCY LIGHTING INVERTER
Keep the lights "ON" when you need them the most.

Single Phase 2.4 KW - 4.2 KW

Made In The USA 

Defends your environment against unwanted power outage and electrical disturbances by providing:

- DSPM Watchdog software always on guard.
- Display monitor keeps you in control 24/7.
- Dependable DSP/PWM technology for unsurpassed reliability.
- Economical for the lowest overall cost for your light safety, with an Energy Star Rating.
- Temperature compensating technology that controls batteries for the longest battery life.
- Sealed maintenance free batteries.
- Full light output for entire 90 minutes.
- Self-diagnostics for a safe and secure lighted environment.
- Pure sine wave output for all types of lamps.
- ECM module is a patented technology used by DSPM.
- Backup solutions for multiple applications such as: indoor and outdoor emergency lighting, exits, cash registers, computers, strategic electronics and more!
- 10 Year pro-rated battery warranty.
- 5 Year power train warranty.
- Meets federal, state and local codes: UL924, NFPA 101, NFPA 70, NEC and OSHA.
- Cities of Chicago and New York Approved.

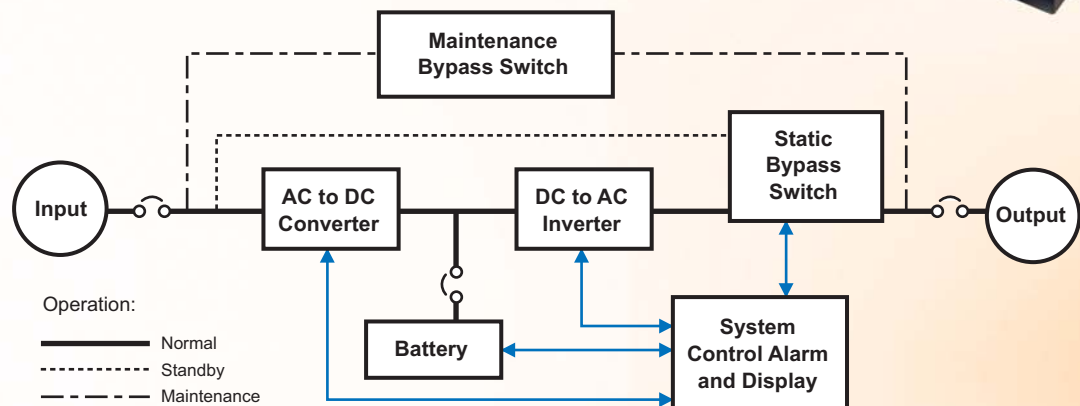

Email: info@DSPManufacturing.com
 1921 S. Quaker Ridge Place
 Ontario, CA 91761
 Ph: 1.877.DSPM POWER
 1.877.377.6769
 Fax: 909.930.3335

DEFENDER PLUS



- *Standard Power Level.....2.4, 2.6, 3.0, 3.4, 3.8 and 4.2 KW
 - *Input Voltage120, 208, 240 or 277 VAC
 - *Input Voltage Range.....+10%. -15%
 - *Output Voltage.....120, 277, 120/240 or 120/277 VAC
 - *Output Voltage Regulation.....±3% for all loads and battery discharge mode
 - *Output Frequency Range.....60 Hz, ±1%
 - Output Wave Form.....Sine-wave <5% @ 100% linear load
 - Crest Factor.....2.5:1 typical
 - Input Protection.....Input Main Circuit Breaker
 - Output Protection.....Output Main Circuit Breaker
 - Surge Protection.....The unit will protect itself and the load against surges as defined in ANSI/IEEE C62.45 category A and B
 - Battery.....Sealed maintenance-free (AGM) lead calcium
 - Recharge Current.....Conforms to UL924 standards
 - External Battery.....Provision for hardware connection of external battery cabinets or DC source
 - Efficiency.....≥92% at 100% linear load
 - Audible Noise.....<45dB measured on Response Curve "A"
 - Safety Agencies.....Listed to UL standard 924
 - Operating Temperature.....0° to 40°C (32° to 104°F)
 - Storage Temperature.....-20° to 60°C (-4° to 140°F)
 - Humidity.....5 - 95%, Non-condensing
- *Consult factory for others.
 Specifications subject to change without notice.



Defender Plus Series	Power Rating	UPS			Weight
		Cabinet Dimensions			
DPLUS (Consult factory for others)	KVA/KW	W	H	D	(lbs)
	2.4	26"	44"	26"	700
	2.6	26"	44"	26"	700
	3.0	26"	44"	26"	800
	3.4	26"	44"	26"	800
	3.8	26"	44"	26"	800
4.2	26"	44"	26"	920	

Options:

- ECM - Environmental Control Module
- NOF120 - Normally OFF Circuit 120VAC
- NOF227 - Normally OFF Circuit 277VAC
- NOH120 - Normally OFF "Hold On" 120VAC
- NOH227 - Normally OFF "Hold On" 277VAC
- OCB - Output Circuit Breaker(s)
- SRB - Seismic-Rated Bracket
- STU1 - Onsite Startup
- IDB - Internal Dimmer Bypass
- EMB - External Maintenance Bypass
- EW - Extended Warranty

Represented by: