

Email: info@DSPManufacturing.com
1921 S. Quaker Ridge Place
Ontario, CA 91761
Ph: 1.877.DSPM POWER
1.877.377.6769
Fax: 909.930.3335

DEFENDER 1



ONLINE EMERGENCY LIGHTING INVERTER
Keep the lights "ON" when you need them the most.

Single Phase 4.7 KW - 18 KW

Made In The USA 

Defends your environment against unwanted power outage and electrical disturbances by providing:

- DSPM Watchdog software always on guard.
- Display monitor keeps you in control 24/7.
- Dependable DSP/PWM technology for unsurpassed reliability.
- Economical for the lowest overall cost for your light safety, with an Energy Star Rating.
- Temperature compensating technology that controls batteries for the longest battery life.
- Sealed maintenance free batteries.
- Full light output for entire 90 minutes.
- Self-diagnostics for a safe and secure lighted environment.
- Pure sine wave output for all types of lamps.
- ECM module is a patented technology used by DSPM.
- Backup solutions for multiple applications such as: indoor and outdoor emergency lighting, exits, cash registers, computers, strategic electronics and more!
- 10 Year pro-rated battery warranty.
- 5 Year power train warranty.
- Meets federal, state and local codes: UL924, NFPA 101, NFPA 70, NEC and OSHA.
- Cities of Chicago and New York Approved.

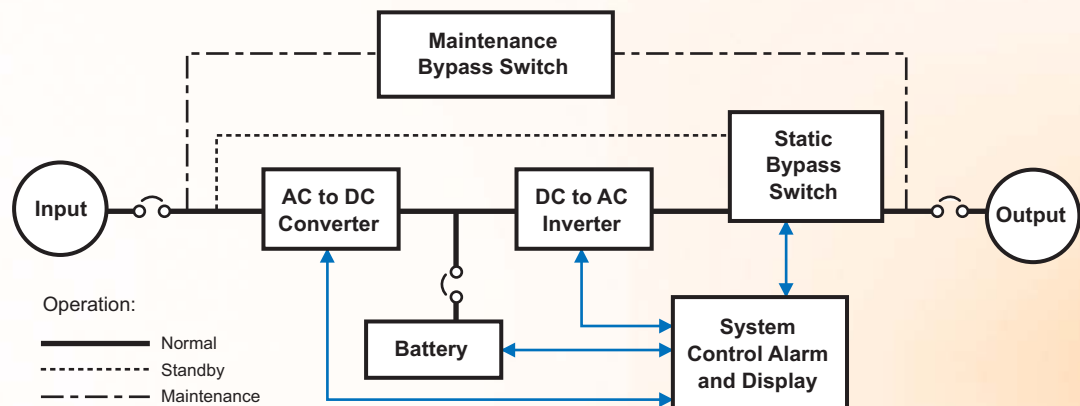

DEFENDER 1



Email: info@DSPManufacturing.com
1921 S. Quaker Ridge Place
Ontario, CA 91761
Ph: 1.877.DSPM POWER
1.877.377.6769
Fax: 909.930.3335

- *Standard Power Levels.....4.7, 5.25, 7.0, 8.0, 10.0, 12.0, 14.0 and 18.0 KW
 - *Input Voltage 120, 208, 240 or 277 VAC
 - *Input Voltage Range.....+10%. -15%
 - *Output Voltage..... 120, 277, 120/240 or 120/277 VAC
 - *Output Voltage Regulation.....±2% for all loads and battery discharge mode
 - *Output Frequency Range.....60 Hz, ±1%
 - Output Wave Form.....Sine-wave <5% @ 100% linear load
 - Crest Factor.....2.5:1 typical
 - Input Protection.....Input Main Circuit Breaker
 - Output Protection.....Output Main Circuit Breaker
 - Surge Protection.....The unit will protect itself and the load against surges as defined in ANSI/IEEE C62.45 category A and B
 - Battery.....Sealed maintenance-free (AGM) lead calcium
 - Recharge Current.....Conforms to UL924 standards
 - External Battery.....Provision for hardware connection of external battery cabinets or DC source
 - Efficiency.....≥92% at 100% linear load
 - Audible Noise.....<45dB measured on Response Curve "A"
 - Safety Agencies.....Listed to UL standard 924
 - Operating Temperature.....0° to 40°C (32° to 104°F)
 - Storage Temperature.....-20° to 60°C (-4° to 140°F)
 - Humidity.....5 - 95%, Non-condensing
- *Consult factory for others.
Specifications subject to change without notice.



Defender 1 Series	Power Rating	UPS			Battery			Weight (combined) (lbs)
		Cabinet Dimensions			Cabinet Dimensions			
DE1 (Consult factory for others)	KVA/KW	W	H	D	W	H	D	
	4.7	42"	71"	22.5"	not required			1200
	5.25	42"	71"	22.5"	not required			1200
	7.0	42"	71"	22.5"	not required			1450
	8.0	42"	71"	22.5"	not required			1450
	10.0	42"	71"	22.5"	not required			1820
	12.0	42"	71"	22.5"	not required			2210
	14.0	42"	71"	22.5"	not required			2550
18.0	42"	71"	22.5"	42"	71"	22.5"	3750	

Options:

- ECM - Environmental Control Module
- NOF120 - Normally OFF Circuit 120VAC
- NOF227 - Normally OFF Circuit 277VAC
- NOH120 - Normally OFF "Hold On" 120VAC
- NOH227 - Normally OFF "Hold On" 277VAC
- OCB - Output Circuit Breaker(s)
- SRB - Seismic-Rated Bracket
- STU1 - Onsite Startup
- IDB - Internal Dimmer Bypass
- EMB - External Maintenance Bypass
- EW - Extended Warranty

Represented by: