

Email: info@DSPManufacturing.com
1921 S. Quaker Ridge Place
Ontario, CA 91761
Ph: 1.877.DSPM POWER
1.877.377.6769
Fax: 909.930.3335

DEFENDER 3



ONLINE EMERGENCY LIGHTING INVERTER
Keep the lights "ON" when you need them the most.

Three Phase 3 KW - 125 KW

Made In The USA 

Defends your environment against unwanted power outage and electrical disturbances by providing:

- DSPM Watchdog software always on guard.
- Display monitor keeps you in control 24/7.
- Dependable DSP/PWM technology for unsurpassed reliability.
- Economical for the lowest overall cost for your light safety, with an Energy Star Rating.
- Temperature compensating technology that controls batteries for the longest battery life.
- Sealed maintenance free batteries.
- Full light output for entire 90 minutes.
- Self-diagnostics for a safe and secure lighted environment.
- Pure sine wave output for all types of lamps.
- ECM module is a patented technology used by DSPM.
- Backup solutions for multiple applications such as: indoor and outdoor emergency lighting, exits, cash registers, computers, strategic electronics and more!
- 10 Year pro-rated battery warranty.
- 5 Year power train warranty.
- Meets federal, state and local codes: UL924, NFPA 101, NFPA 70, NEC and OSHA.
- Cities of Chicago and New York Approved.
- Complies with the Buy American Act.

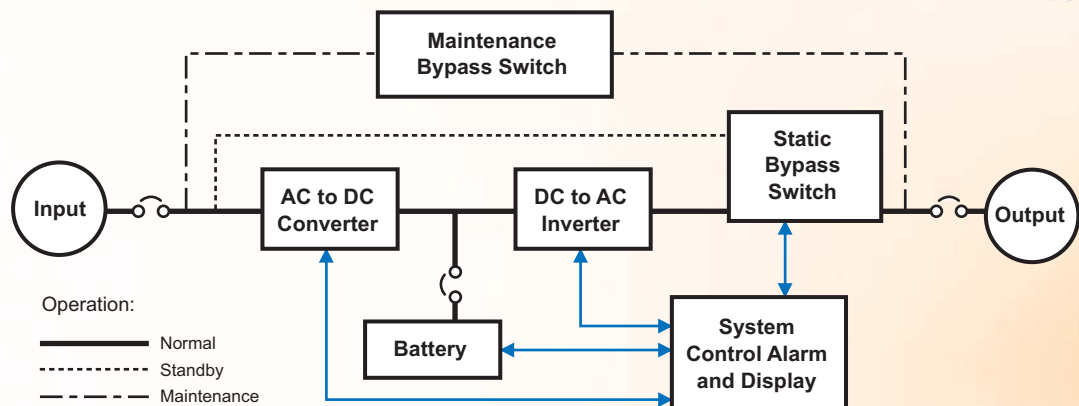

DEFENDER 3

Email: info@DSPManufacturing.com
1921 S. Quaker Ridge Place
Ontario, CA 91761
Ph: 1.877.DSPM POWER
1.877.377.6769
Fax: 909.930.3335



- *Standard Power Levels.....**3.0, 4.5, 6.0, 8.0, 10.0, 12.0, 16.0, 20.0, 24.0, 30.0, 40.0, 60.0, 80.0, 100.0 and 125.0 KW
 - *Input Voltage208Y/120, 480Y/277, 208 or 480VAC
 - *Input Voltage Range.....+10%. -15%
 - *Output Voltage.....208Y/120 or 480Y/277 VAC
 - *Output Voltage Regulation.....±3% for all loads and battery discharge mode
 - *Output Frequency Range.....60 Hz, ±1%
 - Output Wave Form.....Sine-wave <5% @ 100% linear load
 - Crest Factor.....2.5:1 typical
 - Input Protection.....Input Main Circuit Breaker
 - Output Protection.....Output Main Circuit Breaker
 - Surge Protection.....The unit will protect itself and the load against surges as defined in ANSI/IEEE C62.45 category A and B
 - Battery.....Sealed maintenance-free (AGM) lead calcium
 - Recharge Current.....Conforms to UL924 standards
 - External Battery.....Provision for hardware connection of external battery cabinets or DC source
 - Efficiency.....≥92% at 100% linear load
 - Audible Noise.....<45dB measured on Response Curve "A"
 - Safety Agencies.....Listed to UL standard 924
 - Operating Temperature.....0° to 40°C (32° to 104°F)
 - Storage Temperature.....-20° to 60°C (-4° to 140°F)
 - Humidity.....5 - 95%, Non-condensing
- *Consult factory for others.
**No line to line loads for 3.0 - 6.0 kw units.
Specifications subject to change without notice.



Defender 3 Series	Power Rating	UPS			Battery				Weight (combined)
		W	H	D	No.	W	H	D	
DE3 (Consult factory for others)	KVA/KW								(lbs)
	3	42"	71"	22.5"	not required				980
	4.5	42"	71"	22.5"	not required				1100
	6	42"	71"	22.5"	not required				1350
	8	42"	71"	22.5"	1	42"	71"	22.5"	1700
	10	42"	71"	22.5"	1	42"	71"	22.5"	2250
	12	42"	71"	22.5"	1	42"	71"	22.5"	2700
	16	42"	71"	22.5"	1	42"	71"	22.5"	2950
	20	42"	71"	22.5"	2	42"	71"	22.5"	3800
	24	42"	71"	22.5"	2	42"	71"	22.5"	4350
	30	42"	71"	22.5"	2	42"	71"	22.5"	5150
	40	42"	71"	22.5"	3	42"	71"	22.5"	6790
	60	50"	71"	32"	Consult Factory				
	80	50"	71"	32"	Consult Factory				
100	50"	71"	32"	Consult Factory					
125	50"	71"	32"	Consult Factory					

Options:

- ECM - Environmental Control Module
- NOF120 - Normally OFF Circuit 120VAC
- NOF227 - Normally OFF Circuit 277VAC
- NOH120 - Normally OFF "Hold On" 120VAC
- NOH227 - Normally OFF "Hold On" 277VAC
- OCB - Output Circuit Breaker(s)
- EPO - Emergency Power Off
- RSSP - Remote Indicator Panel
- EIR - Ethernet Interface with RS232
- FAX - Fax Modem
- FC - Form C Contacts
- SRB - Seismic-Rated Bracket
- STU3 - Onsite Startup
- IDB - Internal Dimmer Bypass
- EMB - External Maintenance Bypass
- EW - Extended Warranty

Represented by: