

Email: info@DSPManufacturing.com
1921 S. Quaker Ridge Place
Ontario, CA 91761
Ph: 1.877.DSPM POWER
1.877.377.6769
Fax: 909.930.3335

FORTRESS 3



ONLINE OUTDOOR EMERGENCY LIGHTING INVERTER

Keep the lights "ON" when you need them the most.

Three Phase 3 KW - 125 KW

Made In The USA 

Defends your environment against unwanted power outage and electrical disturbances by providing:

- DSPM Watchdog software always on guard.
- Display monitor keeps you in control 24/7.
- Dependable DSP/PWM technology for unsurpassed reliability.
- Economical for the lowest overall cost for your light safety, with an Energy Star Rating.
- Temperature compensating technology that controls batteries for the longest battery life.
- Sealed maintenance free batteries.
- Full light output for entire 90 minutes.
- Self-diagnostics for a safe and secure lighted environment.
- Pure sine wave output for all types of lamps.
- ECM module is a patented technology used by DSPM.
- Backup solutions for multiple applications such as: indoor and outdoor emergency lighting, exits, cash registers, computers, strategic electronics and more!
- 10 Year pro-rated battery warranty.
- 5 Year power train warranty.
- Meets federal, state and local codes: UL924, NFPA 101, NFPA 70, NEC and OSHA.
- Cities of Chicago and New York Approved.
- Complies with the Buy American Act.

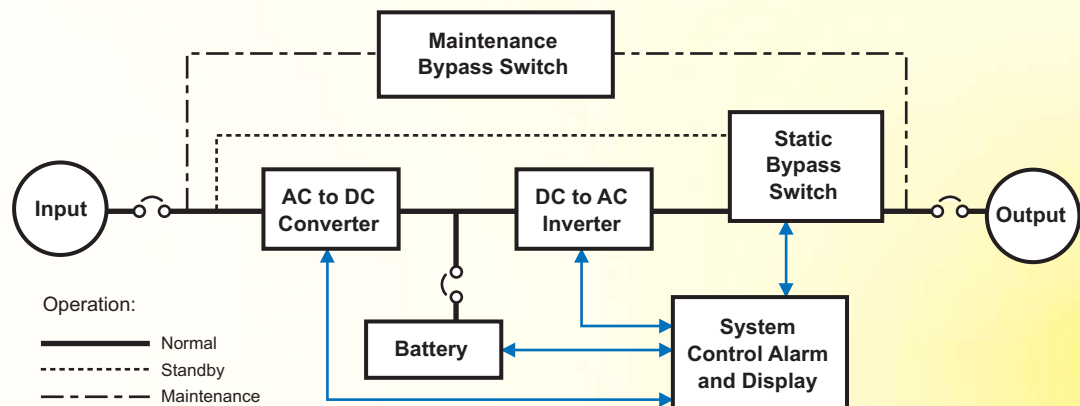

FORTRESS 3



DSPM INC.
DIGITAL SIGNAL POWER MANUFACTURER
www.DSPManufacturing.com

Email: info@DSPManufacturing.com
1921 S. Quaker Ridge Place
Ontario, CA 91761
Ph: 1.877.DSPM POWER
1.877.377.6769
Fax: 909.930.3335

- *Standard Power Levels.....3.0, 4.5, 6.0, 8.0, 10.0, 12.0, 16.0, 20.0, 24.0,
30.0, 40.0, 60.0, 80.0, 100.0 and 125.0 KW
- *Input Voltage208Y/120, 480Y/277, 208 or 480VAC
- *Input Voltage Range.....+10%. -15%
- *Output Voltage.....208Y/120 or 480Y/277 VAC
- *Output Voltage Regulation.....±3% for all loads and battery discharge mode
- *Output Frequency Range.....60 Hz, ±1%
- Output Wave Form.....Sine-wave <5% @ 100% linear load
- Crest Factor.....2.5:1 typical
- Input Protection.....Input Main Circuit Breaker
- Output Protection.....Output Main Circuit Breaker
- Surge Protection.....The unit will protect itself and the load
against surges as defined in
ANSI/IEEE C62.45 category A and B
- Battery.....Sealed maintenance-free (AGM) lead calcium
- Recharge Current.....Conforms to UL924 standards
- External Battery.....Provision for hardware connection of
external battery cabinets or DC source
- Efficiency.....≥92% at 100% linear load
- Audible Noise.....<45dB measured on Response Curve "A"
- Safety Agencies.....Listed to UL standard 924
- Operating Temperature.....-20° to 50°C (-4° to 122°F)
- Storage Temperature.....-20° to 60°C (-4° to 140°F)
- Humidity.....5 - 100%, Non-condensing
- Cabinet.....NEMA 3R

*Consult factory for others.

Specifications subject to change without notice.



Fortress Outdoor 3	Power Rating	UPS			Battery				Weight (com- bined)	
		Cabinet Dimensions			Cabinet Dimensions					
	KVA/KW	W	H	D	No.	W	H	D	(lbs)	
FT3 (Consult factory for other capabilities)	3	41"	48"	32"	not required				1480	
	4.5	41"	72"	32"	not required				1600	
	6	41"	72"	32"	not required				1850	
	8	41"	72"	32"	not required				2200	
	10	41"	72"	32"	not required				2750	
	12	41"	72"	32"	1	41"	72"	32"	3200	
	16	41"	72"	32"	1	41"	72"	32"	3450	
	20	41"	72"	32"	1	41"	72"	32"	4300	
	24	41"	72"	32"	2	41"	72"	32"	5050	
	30	41"	72"	32"	2	41"	72"	32"	5900	
	40	41"	72"	32"	3	41"	72"	32"	6750	
	60	Consult Factory								
	80	Consult Factory								
	100	Consult Factory								
125	Consult Factory									

Options:

- ECM - Environmental Control Module
- NOF120 - Normally OFF Circuit 120VAC
- NOF227 - Normally OFF Circuit 277VAC
- NOH120 - Normally OFF "Hold On" 120VAC
- NOH227 - Normally OFF "Hold On" 277VAC
- OCB - Output Circuit Breaker(s)
- EPO - Emergency Power Off
- RSSP - Remote Indicator Panel
- EIR - Ethernet Interface with RS232
- FAX - Fax Modem
- FC - Form C Contacts
- STU3 - Onsite Startup
- IDB - Internal Dimmer Bypass
- EMB - External Maintenance Bypass
- HE - Heat Exchanger
- HTR - Heater
- EW - Extended Warranty

Represented by: