

# PIRANHA



## INDOOR POWER CONDITIONING VOLTAGE REGULATOR

Take a Bite out of Power Problems.

### Three Phase 10 - 250 kVA

Made In The USA 

*Defends your environment against unwanted power problems by providing:*

- Display monitor keeps you in control 24/7.
- Dependable DSP/PWM technology for unsurpassed reliability.
- Economical for the lowest overall cost for your light safety, with an Energy Star Rating.
- High efficiency of >96%.
- A reliability of over 200,000 hours.
- Comes standard with a main input breaker.
- Easy front access.
- With a proven non-linear load capability.
- Standard manual bypass switch.
- Input and output filters.
- 5 Year power train warranty.
- Listed UL 1950.
- Complies with the Buy American Act.

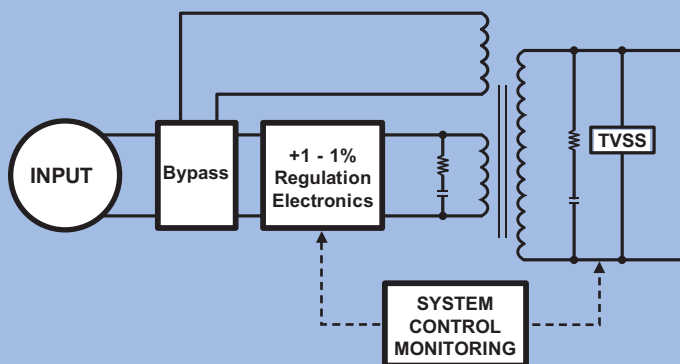

 **DSPM** INC.  
DIGITAL SIGNAL POWER MANUFACTURER  
[www.DSPManufacturing.com](http://www.DSPManufacturing.com)

Email: [info@DSPManufacturing.com](mailto:info@DSPManufacturing.com)  
1921 S. Quaker Ridge Place  
Ontario, CA 91761  
Ph: 1.877.DSPM POWER  
1.877.377.6769  
Fax: 909.930.3335

# PIRANHA



- \*Standard Power Levels.....10, 20, 30, 50, 75, 100, 125, 150, 250 kVA
  - \*Input Voltage .....208, 240 or 480 VAC
  - \*Input Voltage Range.....+10%, -15%
  - Power Factor.....0.95
  - \*Frequency Range.....50, 60 or 400 Hz
  - \*Output Voltage.....120/240, 208Y/120 or 480Y/277 VAC
  - \*Output Voltage Regulation.....±1% Typical, ±2% Max
  - Response Time.....1 Cycle correction with standard regulation
  - Harmonic Distortion.....<1% Added
  - Common Mode.....-152 dB
  - Normal Mode.....-60 dB (0.1 Hz to 1 mHz)
  - Overload (Inrush).....200% of full load for 10 seconds
  - Transformer.....Shielded, isolation transformer or copper wound,  
buck-boost transformer
  - Efficiency.....≥96% at full loads; 98.5% at light loads
  - Load Power Factor.....0.3 Leading or lagging to unity
  - Audible Noise.....<58 dB measured on Response Curve "A"
  - Safety Agencies.....Listed to UL standard 1950
  - Operating Temperature.....0° to 40°C (32° to 104°F)
  - Storage Temperature.....-20° to 60°C (-4° to 140°F)
  - Humidity.....0 - 95%, Non-condensing
  - \*Consult factory for others.
- Specifications subject to change without notice.

Piranha Indoor Series	Power Rating	Cabinet Dimensions			Weight (lbs)	BTU's
		W	H	D		
PIR3	kVA					
	10	42"	71"	22.5"	400	2060
	20	42"	71"	22.5"	450	3075
	30	42"	71"	22.5"	500	4090
	50	42"	71"	22.5"	700	7447
	75	42"	71"	22.5"	900	10800
	100	42"	71"	22.5"	1150	13790
	125	42"	71"	22.5"	1313	17195
	150	42"	71"	22.5"	1475	20600
250	50.5"	66"	32"	2350	33400	



**Options:**

- OTCB - Output Circuit Breakers
- TVSS - Transient Voltage Surge Suppressor
- STU3 - Onsite Startup
- EW - Extended Warranty



Represented by:

Email: info@DSPManufacturing.com  
 1921 S. Quaker Ridge Place  
 Ontario, CA 91761  
 Ph: 1.877.DSPM POWER  
 1.877.377.6769  
 Fax: 909.930.3335