

PIRANHA



OUTDOOR POWER CONDITIONING VOLTAGE REGULATOR

Take a Bite out of Power Problems.

Three Phase 10 - 250 kVA

Made In The USA 

Defends your environment against unwanted power problems by providing:

- Display monitor keeps you in control 24/7.
- Dependable DSP/PWM technology for unsurpassed reliability.
- Economical for the lowest overall cost for your light safety, with an Energy Star Rating.
- High efficiency of >96%.
- A reliability of over 200,000 hours.
- Comes standard with a main input breaker.
- Easy front access with key locks for added protection.
- With a proven non-linear load capability.
- Standard manual bypass switch.
- Input and output filters.
- 5 Year power train warranty.
- Listed UL 1950.
- Complies with the Buy American Act.

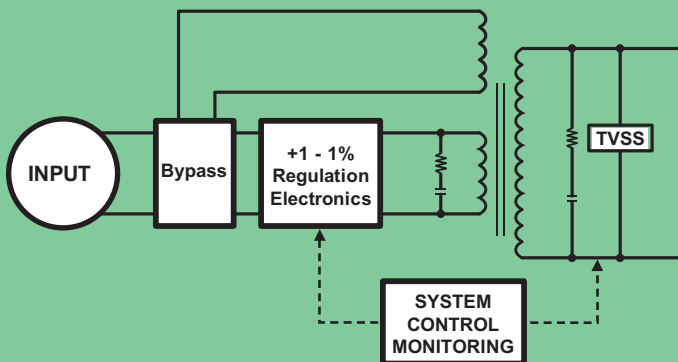

 **DSPM** INC.
DIGITAL SIGNAL POWER MANUFACTURER
www.DSPManufacturing.com

Email: info@DSPManufacturing.com
1921 S. Quaker Ridge Place
Ontario, CA 91761
Ph: 1.877.DSPM POWER
1.877.377.6769
Fax: 909.930.3335

PIRANHA



- *Standard Power Levels.....10, 20, 30, 50, 75, 100, 125, 150, 250 kVA
 - *Input Voltage208, 240 or 480 VAC
 - *Input Voltage Range.....+10%, -15%
 - Power Factor.....0.95
 - *Frequency Range.....50, 60 or 400 Hz
 - *Output Voltage.....120/240, 208Y/120 or 480Y/277 VAC
 - *Output Voltage Regulation.....±1% Typical, ±2% Max
 - Response Time.....1 Cycle correction with standard regulation
 - Harmonic Distortion.....<1% Added
 - Common Mode.....-152 dB
 - Normal Mode.....-60 dB (0.1 Hz to 1 mHz)
 - Overload (Inrush).....200% of full load for 10 seconds
 - Transformer.....Shielded, isolation transformer or copper wound, buck-boost transformer
 - Efficiency.....≥96% at full loads; 98.5% at light loads
 - Load Power Factor.....0.3 Leading or lagging to unity
 - Audible Noise.....<58 dB measured on Response Curve "A"
 - Safety Agencies.....Listed to UL standard 1950
 - Operating Temperature.....-20° to 50°C (-4° to 122°F)
 - Storage Temperature.....-20° to 60°C (-4° to 140°F)
 - Humidity.....5 - 100%, Non-condensing
 - Cabinet.....NEMA 3R
- *Consult factory for others.
Specifications subject to change without notice.

Piranha Outdoor Series	Power Rating	Cabinet Dimensions			Weight (lbs)	BTU's
		W	H	D		
POR3	kVA					
	10	41"	72"	32"	500	2060
	20	41"	72"	32"	550	3075
	30	41"	72"	32"	600	4090
	50	41"	72"	32"	800	7447
	75	41"	72"	32"	1000	10800
	100	41"	72"	32"	1250	13790
	125	41"	72"	32"	1413	17195
	150	41"	72"	32"	1525	20600
250	50.5"	66"	32"	2450	33400	



Options:

- OTCB - Output Circuit Breakers
- TVSS - Transient Voltage Surge Suppressor
- STU3 - Onsite Startup
- EW - Extended Warranty



Represented by:

Email: info@DSPManufacturing.com
 1921 S. Quaker Ridge Place
 Ontario, CA 91761
 Ph: 1.877.DSPM POWER
 1.877.377.6769
 Fax: 909.930.3335