

DESCRIPTION

The Piranha provides the ultimate in power conditioning voltage regulation and is designed to be fully field supported. The Piranha comes standard with a manual bypass switch that enables the unit to operate keeping you on-line when you need it most!

*POWER RATING

- 10 kVA - 250 kVA three phase output unit uses the latest technology to provide the most advanced performance and reliability features

*INPUT

- 208, 240 or 480 VAC
- Regulation Range of +10%, -15%
- 0.95 Power Factor

*OUTPUT

- 120/240, 208Y/120 or 480Y/277 VAC output 60 Hz
- Voltage regulation $\pm 1\%$ typical, $\pm 2\%$ max

LOADS

- Offers a Subcycle Voltage correction
- Maintains a "Peak to RMS" ratio ≥ 3 to 1

CODES

- Listed to UL standard 1950
- Complies with the Buy American Act

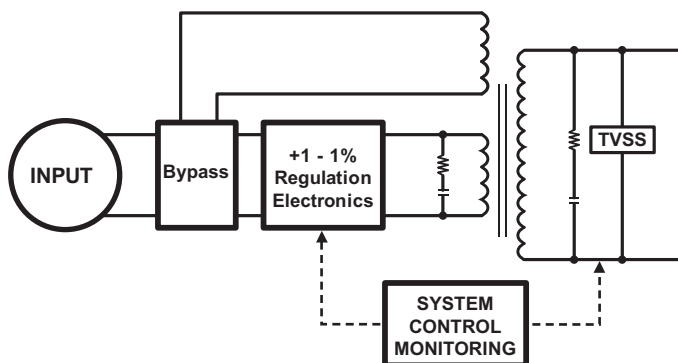

*Consult factory for others.

083-0031-01 Rev. A

Catalog Number	
Project	Notes
Signature	Date

10 kVA - 250 kVA

Three Phase

Outdoor
Power
Conditioning/
Voltage
Regulator



PROTECTION

- Provides overload, surge and undercurrent protection using DSP/PWM technology and DSPM *Watchdog Software* to protect system performance and reliability
- Surge protection against load surges as defined in ANSI/IEEE C62.45 category A and B

DIAGNOSTICS AND MAINTENANCE

- DSP/PWM technology and DSPM *Watchdog Software* provides complete self diagnostic capabilities and LED Monitoring
- Informative advanced Display and Alarms keep you in control of your emergency lighting environment 24/7

NEMA 3R CABINET

- Modular design enables flexible installation
- Forced air cooling for maximum reliability
- All systems are self contained

INSTALLATION

- Modular design and small footprint allow easy installation in electrical closet or other convenient locations
- Phone assisted factory start-up standard for all systems
- Extended warranty available

RELIABILITY

- MTBF greater than 200,000 hours in worst case conditions
- MTTR of less than 2 hours
- The front access control panel makes it easy to maintain and ensures maximum up time

WARRANTY

- 1-Year full warranty on system electronics
- System 1-year on-site warranty labor with DSPM phone assisted start-up
- 5-Year powertrain warranty
- Maintenance contracts available



Piranha Outdoor Series	Power Rating	Cabinet Dimensions			Weight (lbs)	BTU's	Voltage (VAC)	
		W	H	D			Input	Output
POR3	kVA							
	10	41"	72"	32"	500	2060	<i>Select</i> 208, 240 or 480 VAC	<i>Select</i> 120/240, 280Y/120 or 480Y/277 VAC
	20	41"	72"	32"	550	3075		
	30	41"	72"	32"	600	4090		
	50	41"	72"	32"	800	7447		
	75	41"	72"	32"	1000	10800		
	100	41"	72"	32"	1250	13790		
	125	41"	72"	32"	1413	17195		
	150	41"	72"	32"	1525	20600		
250	50.5"	66"	32"	2450	33400			

The *Piranha* offers exceptional reliability with a **Mean Time Between Failure** greater than **200,000 hours** in worst case conditions and **Mean Time To Repair** of less than 2 hours. The front access control makes it easy to maintain and ensures maximum up time.

The *Piranha* from **DSPM** "Takes a Bite Out of Power Problems".

ORDERING INFORMATION

Choose the bold face catalog nomenclature that best suites your needs.

Write them on the appropriate line. Order accessories as separate catalog number.

Example:

POR3 - 30 - 240 208Y/120 - TVSS EW

Description of example:

(30 kVA, 240 Voltage In, 208Y/120 Voltage Out, Transient Voltage Surge Suppressor, Extended Warranty)

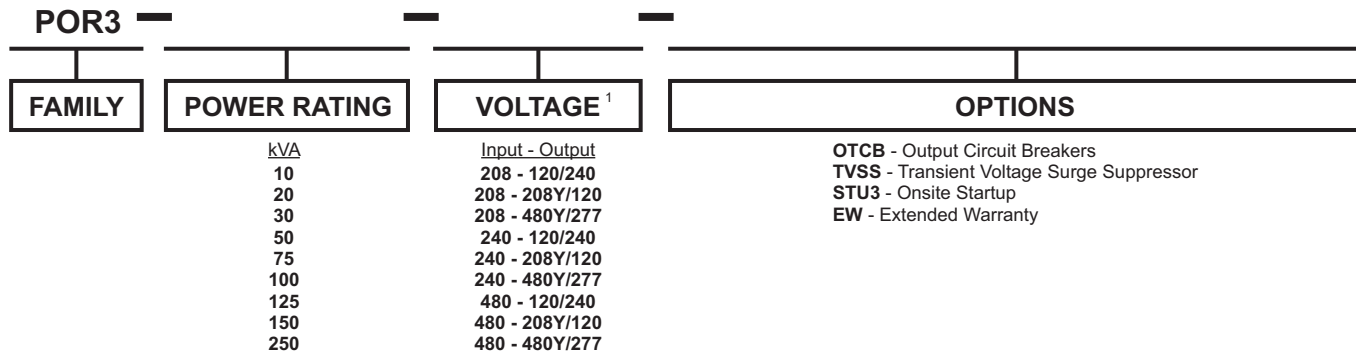

NOTES:

1-Consult factory for other voltage requirements. Special voltages may effect the weight, size and number of cabinets.

Specifications subject to change without notice.



1921 S. Quaker Ridge Place
Ontario, CA 91761
Ph: 1.877.DSPM POWER
1.877.377.6769
Fax: 909.930.3335