

POWER LYNX 3



HARSH ENVIRONMENT UNINTERRUPTABLE POWER SYSTEM

Providing power without interruption.

Three Phase 15 kVA - 125 kVA

Made In The USA 

Defends your environment against unwanted electrical disturbances by providing:

- DSPM Watchdog software always on guard.
- Display monitor keeps you in control 24/7.
- Dependable DSP/PWM technology for unsurpassed reliability.
- Economical for the lowest overall cost with an Energy Star Rating.
- High efficiency of >92%, with an reliability of 200,000 hours.
- Temperature compensating technology that controls batteries for the longest battery life.
- A proven non-linear load capability.
- Provides continuous AC voltage without interruption.
- Microprocessor that stores any alarm so a history is always available.
- Sealed maintenance free batteries.
- 10 Year pro-rated battery warranty.
- 5 Year power train warranty.
- Meets federal, state and local code, UL1778.
- Complies with the Buy American Act.

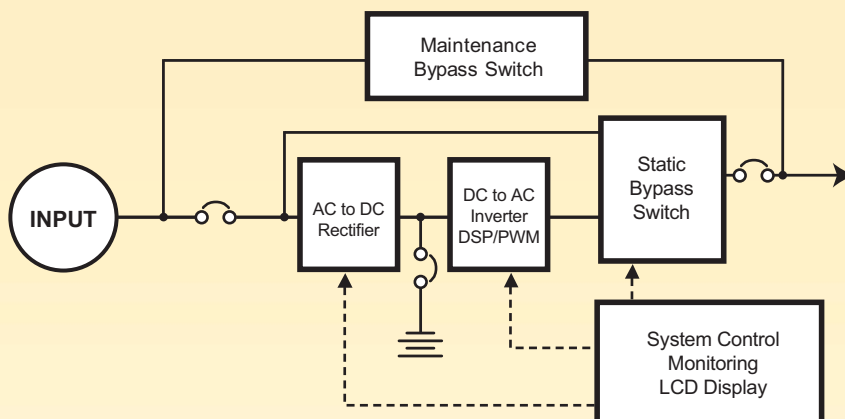

 **DSPM** INC.
DIGITAL SIGNAL POWER MANUFACTURER
www.DSPManufacturing.com

Email: info@DSPManufacturing.com
1921 S. Quaker Ridge Place
Ontario, CA 91761
Ph: 1.877.DSPM POWER
1.877.377.6769
Fax: 909.930.3335

POWER LYNX 3



- *Standard Power Levels.....15, 30, 50, 75, 100 and 125 kVA
- *Input Voltage208Y/120, 480Y/277, 208 or 480 VAC
- *Input Voltage Range.....+10% - 15%
- *Output Voltage.....208Y/120 or 480Y/277 VAC
- *Output Voltage Regulation.....±2% typical
- *Output Frequency Range.....60 Hz, ±5%
- Output Wave Form.....Sine-wave <5% @ 100% linear load
- Crest Factor.....2.5:1 typical
- Input Protection.....Input Main Circuit Breaker
- Output Protection.....Output Main Circuit Breaker
- Surge Protection.....The unit will protect itself and the load against surges as defined in ANSI/IEEE C62.45 category A and B
- Battery.....Sealed maintenance-free (AGM) lead calcium
- Recharge Current.....10x discharge
- External Battery.....Provision for hardware connection of external battery cabinets or DC source
- Efficiency.....≥92%
- Audible Noise.....<45dB measured on Response Curve "A"
- Safety Agencies.....Listed to UL standard 1778
- Operating Temperature.....-20° to 60°C (-4° to 140°F)
- Storage Temperature.....-20° to 60°C (-4° to 140°F)
- Humidity.....5 - 95%, Non-condensing
- Cabinet.....NEMA 4X or 12

*Consult factory for others.
Specifications subject to change without notice.



| Power Lynx Series | Power Rating | Total Watts | UPS | | | Battery | | | Weight (combined) |
|---|--------------|-------------|--------------------|-----|-----|--------------------|-----|-----|-------------------|
| | | | Cabinet Dimensions | | | Cabinet Dimensions | | | |
| | kVA | KW | W | H | D | W | H | D | (lbs) |
| PLH3 <small>(Consult factory for others)</small> | 15 | 12 | 41" | 72" | 32" | not required | | | 2050 |
| | 30 | 24 | 41" | 72" | 32" | not required | | | 2500 |
| | 50 | 40 | 41" | 72" | 32" | 41" | 72" | 32" | 3530 |
| | 75 | 60 | 41" | 72" | 32" | 41" | 72" | 32" | 3750 |
| | 100 | 80 | 41" | 72" | 32" | 41" | 72" | 32" | 4300 |
| | 125 | 100 | 41" | 72" | 32" | 41" | 72" | 32" | 4700 |

Options:

- RSSP - Remote Indicator Panel
- SNMP - SNMP Card
- FC - Form C Contacts
- OCB - Output Circuit Breaker(s)
- SRB - Seismic-Rated Bracket
- EMB - External Maintenance Bypass
- HTR - Heater
- EW - Extended Warranty



Email: info@DSPManufacturing.com
 1921 S. Quaker Ridge Place
 Ontario, CA 91761
 Ph: 1.877.DSPM POWER
 1.877.377.6769
 Fax: 909.930.3335

Represented by: