

## SPECIFICATIONS

The Power Lynx 1 maintains efficient AC Power eliminating noise, spikes, surges and brownouts. When the utility fails the unit will continue to provide AC voltage without the slightest interruption.

### POWER RATING

- 3 kVA - 18 kVA single phase output unit that uses the latest DSP/PWM technology to provide the most advanced performance and reliability features

### INPUT

- 120, 208, 240, 277 or 480 VAC

### OUTPUT

- 120, 208, 240, 277, 480 or 120/240VAC,  $\geq 92\%$  efficient at 100% linear load

### BATTERIES

- Sealed, maintenance-free, lead calcium (AGM) batteries
- 10-Year prorated warranty
- DSP/PWM Smart Battery Monitoring System is **TEMPERATURE COMPENSATED** maintaining maximum runtime and battery life
- Microprocessor controlled recharge and DSP/PWM overcharge protection standard

### CODES

- Listed to UL 1778
- Complies with the Buy American Act

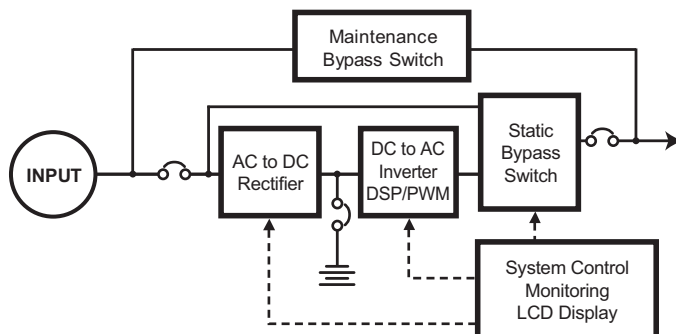

Catalog Number	
Project	Notes
Signature	Date

3 kVA - 18 kVA

Single Phase

Harsh  
Environment  
Uninterrupted  
Power  
Systems



### PROTECTION

- Provides overload, surge and undercurrent protection using DSP/PWM technology and DSPM Watchdog Software to protect system performance and reliability
- Surge protection against load surges as defined in ANSI/IEEE C62.45 category A and B

### DIAGNOSTICS AND MAINTENANCE

- DSP/PWM technology and DSPM Watchdog Software provides complete self diagnostic capabilities and LED Monitoring
- Informative advanced Display and Alarms keep you in control of your environment 24/7
- Automatically performs periodic self-tests
- Single point of testing instead of multiple testing points with battery packs

### NEMA 4X or 12 CABINET

- Modular design enables flexible installation
- Forced air cooling for maximum reliability
- All systems are self contained

### INSTALLATION

- Modular design and small footprint allow easy installation in electrical closet or other convenient locations
- Factory start-up standard for all systems
- Extended warranty available

### WARRANTY

- 1-Year full warranty on system electronics
- Battery warranty 1-year with 9-years pro-rated
- System 1-year on-site warranty labor with DSPM phone assisted start-up
- 5-Year powertrain warranty
- Maintenance contracts available



Power Lynx Series	Power Rating	Total Watts	UPS Cabinet Dimensions			Weight (lbs)	Battery Type	Voltage (VAC)		Output Protection	
			W	H	D			Input	Output		
PLH1	kVA	KW	W	H	D	(lbs)	Sealed, Maintenance free (AGM) lead calcium	Input	Output	Input and output circuit breakers standard	
	3	2.0	41"	48"	32"	1025					<i>Select</i> 120, 208, 240, 277, 480 or 120/240 (Consult factory for others)
	5	3.5	41"	48"	32"	1070					
	7.5	5.25	41"	48"	32"	1270					
	10	7.0	41"	48"	32"	1370					
	12.5	8.75	41"	48"	32"	1420					
	15	10.5	41"	48"	32"	1495					
18	12.6	41"	48"	32"	1695						

The Power Lynx 1 is always on-line eliminating noise, spikes, surges and brownouts. When the utility fails, the PLH1 will continue to provide AC voltage without the slightest interruption. The PLH1 generates an output sine wave that uses a high frequency PWM. The output Transformer isolates your critical load from any source of noise, so that your equipment is always protected. It's comprehensive monitoring checks each output, and input individually so you always know what is going on with your critical load. Alarm settings are field adjustable via the front panel. A microprocessor will store any alarm so a history is always available.

You deserve the **peace of mind** that the Power Lynx from **DSPM** ensures.

## ORDERING INFORMATION

Choose the bold face catalog nomenclature that best suites your needs.

Write them on the appropriate line. Order accessories as separate catalog number.

Example:

**PLH1 - 7.5 - 208 240- EMB OCB**

Description of example:

(7.5 kVA, 208 Voltage In, 240 Voltage Out, External Maintenance Bypass Switch, Output Circuit Breakers)

PLH1	FAMILY	POWER RATING	VOLTAGE <sup>1</sup>		OPTIONS	TIME
		kVA	Input - Output	Input - Output	RSSP - Remote Indicator Panel	Minutes
		3	120/120	277/120	SNMP - SNMP Card	5 (Standard)
		5	120/277	277/277	FC - Form C Contacts	10
		7.5	120/480	277/480	OCB - Output Circuit Breaker(s)	15
		10	120/120-240	277/120-240	SRB - Seismic rated bracket	20
		12.5	120/120-277	277/120-277	EMB - External maintenance bypass switch	25
		15	208/120	480/120	HTR - Heater	30
		18	208/277	480/277	EW - Extended warranty	45
			208/480	480/480		60
			208/120-240	480/120-240		120
			208/120-277	480/120-277		180
			240/120			
			240/277			
			240/480			
			240/120-240			
			240/120-277			

### NOTES:

1-Consult factory for other voltage requirements. Special voltages may effect the weight, size and number of cabinets.

2-One ECM is used per switching device or circuit.

Specifications subject to change without notice.



1921 S. Quaker Ridge Place  
 Ontario, CA 91761  
 Ph: 1.877.DSPM POWER  
 1.877.377.6769  
 Fax: 909.930.3335