



ISOLATION TRANSFORMER

SPECIFICATIONS

- The Isolation Transformer 3 maintains efficient power to operate even with the worst of power problems, providing superior dependability and reliability commercial/industrial environments in a small footprint.

POWER RATING

- 15 kVA - 500 kVA three phase output unit uses the latest DSP/PWM technology to provide the most advanced

PROTECTION

- Provides overload, surge and undercurrent protection.
- Surge protection against load surges as defined in ANSI/IEEE C62.45 category A and B

INPUT

- 208 or 480 VAC input 50-60Hz

OUTPUT

- 208Y/120 or 480Y/277VAC
- <200 nanoseconds response time

CODES

- Meets NFPA 101, NFPA 70, NEC and OSHA standards



10 kVA - 500 kVA

Three Phase

Isolation

Transformer

DIAGNOSTICS AND MAINTENANCE

- DSP/PWM technology and DSPM Watchdog Software provides complete self diagnostic capabilities and LED Monitoring.
- Informative advanced Display and Alarms keep you in control of your emergency lighting environment 24/7.

WARRANTY

- 1-Year full warranty on system electronics
- System 1-year on-site warranty labor with DSPM phone assisted start-up
- 5-Year powertrain warranty
- Maintenance contracts available

CABINET

- Modular design enables flexible installation
- Forced air cooling for maximum reliability
- All systems are self contained

INSTALLATION

- Modular design and small footprint allow easy installation in electrical closet or other convenient locations
- Phone assisted factory start-up standard for all systems
- Extended warranty available

SPECIAL APPLICATIONS

- DSPM offers numerous UL924 optional devices to meet unusual or difficult application parameters
- ECM - Environmental Circuit Module allows fixtures and lamps on the emergency circuit(s) to be operated by normal switching and/or dimming devices in NON-emergency conditions
- Dimming Panel Interface allows use with emergency lights controlled by common dimmer panel

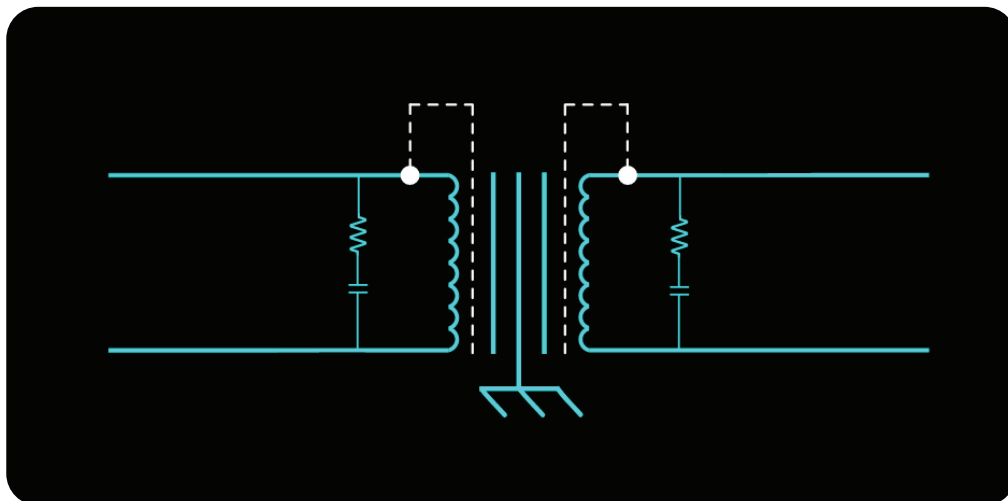

Isolation Transformer Series	Power Rating	Cabinet Dimensions			Weight	BTU	Voltage (VAC)		Efficiency	Standard Features
		W	H	D			Input	Output		
ISO3 (Consult factory for others)	kVA	W	H	D	(lbs)		208 or 480	208Y/120 or 408/277	96% at full loads; 98% at light loads	Common-Mode Noise Attenuation -120 dB Normal-Mode Noise Attenuation -20 dB/decade
	15	21"	28"	14"	300	2040				
	30	26.5"	32"	17"	420	4080				
	50	26.5"	32"	17"	530	6800				
	75	31.5"	40.5"	21.75"	670	10200				
	100	31.5"	40.5"	21.75"	800	13600				
	125	31.5"	40.5"	21.75"	890	17000				
	150	40.5"	51.5"	26.5"	970	20400				
	175	40.5"	51.5"	26.5"	1150	23800				
	200	40.5"	51.5"	26.5"	1300	27200				
	225	40.5"	51.5"	26.5"	1400	30600				
	250	40.5"	51.5"	26.5"	1500	34000				
	300	40.5"	51.5"	26.5"	1700	40800				
	400	50.5"	66"	32"	2350	54400				
500	50.5"	66"	32"	2550	68000					

The Isolation Transformer 3 protects against switching power supplies, electrical noise, dirty power, transverse voltage and voltage disturbances. The ISO3 helps protect your computers and other sensitive equipment from the worst of any electrical problem. Along with protecting your printers, data transfers and sensitive circuit components.

The ISO3 has 3 - 5% low impedance that minimizes the distortions, and 2 Faraday shield.

You deserve the **peace of mind** that the Isolations Transformer from **DSPM** ensures.

ORDERING INFORMATION

Choose the bold face catalog nomenclature that best suites your needs.

Write them on the appropriate line. Order accessories as separate catalog number.

Example:

ISO3 - 50 - 208 208Y/120- HIT EW

Description of example:

(50 kVA, 208 Voltage In, 208Y/120 Voltage Out, High Isolation Transformer, Extended Warranty)

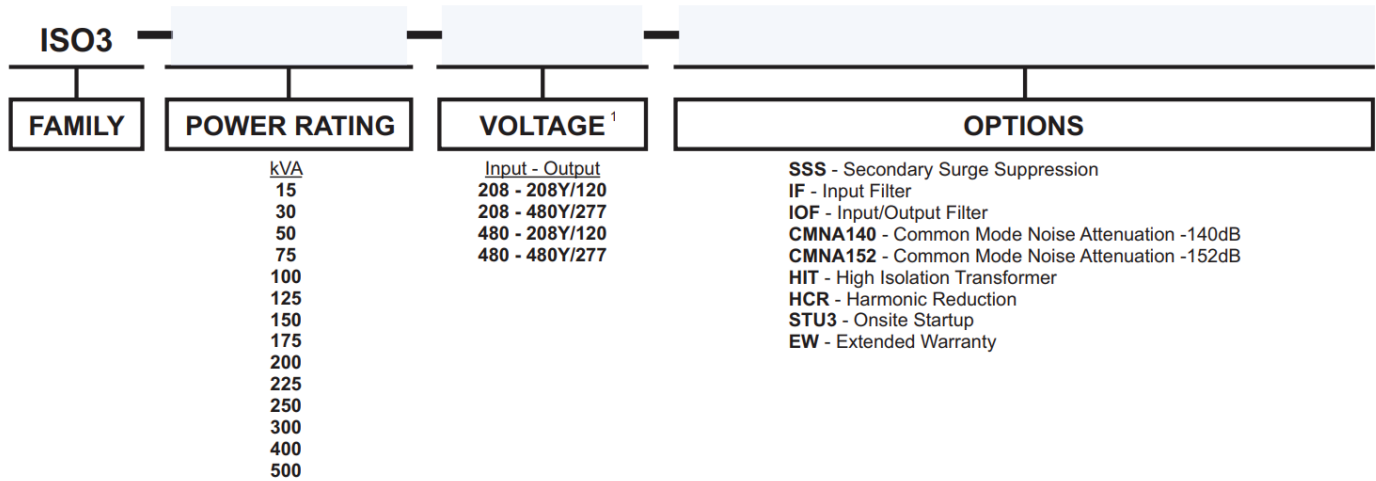

NOTES:

1-Consult factory for other voltage requirements. Special voltages

may effect the weight, size and number or cabinets.

Specifications subject to change without notice.