

# POWER LYNX 3



## HARSH ENVIRONMENT UNINTERRUPTABLE POWER SYSTEM

Providing power without interruption.

### Three Phase 15 kVA - 125 kVA

Made In The USA 

*Defends your environment against unwanted electrical disturbances by providing:*

- DSPM Watchdog software always on guard.
- Display monitor keeps you in control 24/7.
- Dependable DSP/PWM technology for unsurpassed reliability.
- Economical for the lowest overall cost with an Energy Star Rating.
- High efficiency of >92%, with an reliability of 200,000 hours.
- Temperature compensating technology that controls batteries for the longest battery life.
- A proven non-linear load capability.
- Provides continuous AC voltage without interruption.
- Microprocessor that stores any alarm so a history is always available.
- Sealed maintenance free batteries.
- 10 Year pro-rated battery warranty.
- 5 Year power train warranty.
- Meets federal, state and local code, UL1778.
- Complies with the Buy American Act.

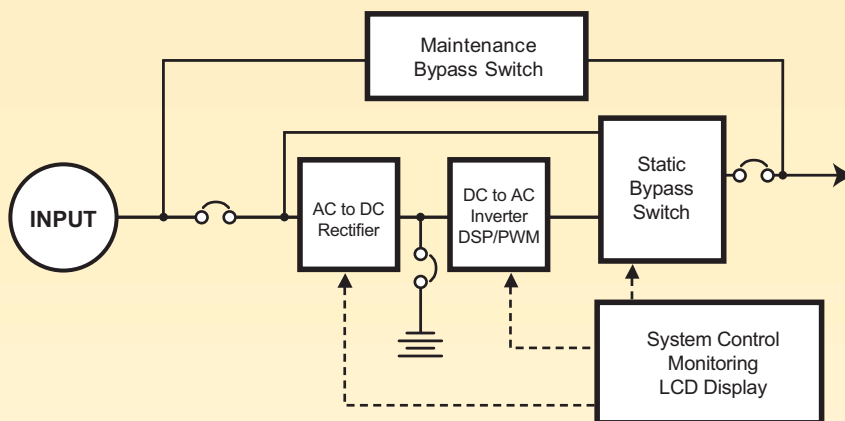

 **DSPM** INC.  
DIGITAL SIGNAL POWER MANUFACTURER  
www.DSPManufacturing.com

Email: [info@DSPManufacturing.com](mailto:info@DSPManufacturing.com)  
1921 S. Quaker Ridge Place  
Ontario, CA 91761  
Ph: 1.877.DSPM POWER  
1.877.377.6769  
Fax: 909.930.3335

# POWER LYNX 3



- \*Standard Power Levels.....15, 30, 50, 75, 100 and 125 kVA
- \*Input Voltage .....208Y/120, 480Y/277, 208 or 480 VAC
- \*Input Voltage Range.....+10% - 15%
- \*Output Voltage.....208Y/120 or 480Y/277 VAC
- \*Output Voltage Regulation.....±2% typical
- \*Output Frequency Range.....60 Hz, ±5%
- Output Wave Form.....Sine-wave <5% @ 100% linear load
- Crest Factor.....2.5:1 typical
- Input Protection.....Input Main Circuit Breaker
- Output Protection.....Output Main Circuit Breaker
- Surge Protection.....The unit will protect itself and the load against surges as defined in ANSI/IEEE C62.45 category A and B
- Battery.....Sealed maintenance-free (AGM) lead calcium
- Recharge Current.....10x discharge
- External Battery.....Provision for hardware connection of external battery cabinets or DC source
- Efficiency.....≥92%
- Audible Noise.....<45dB measured on Response Curve "A"
- Cul Listed.....Built to UL standard 1778
- Operating Temperature.....-20° to 60°C (-4° to 140°F)
- Storage Temperature.....-20° to 60°C (-4° to 140°F)
- Humidity.....5 - 95%, Non-condensing
- Cabinet.....NEMA 4X or 12

\*Consult factory for others.

Specifications subject to change without notice.



Power Lynx Series	Power Rating	Total Watts	UPS			Battery			Weight (combined)
			Cabinet Dimensions			Cabinet Dimensions			
	kVA	KW	W	H	D	W	H	D	(lbs)
PLH3 (Consult factory for others)	15	12	58"	72.8"	36"	not required			2050
	30	24	58"	72.8"	36"	not required			2500
	50	40	58"	72.8"	36"	58"	72.8"	36"	3530
	75	60	58"	72.8"	36"	58"	72.8"	36"	3750
	100	80	58"	72.8"	36"	58"	72.8"	36"	4300
	125	100	58"	72.8"	36"	58"	72.8"	36"	4700

### Options:

- RSSP - Remote Indicator Panel
- SNMP - SNMP Card
- FC - Form C Contacts
- OCB - Output Circuit Breaker(s)
- SRB - Seismic-Rated Bracket
- EMB - External Maintenance Bypass
- HTR - Heater
- EW - Extended Warranty



Email: info@DSPManufacturing.com  
 1921 S. Quaker Ridge Place  
 Ontario, CA 91761  
 Ph: 1.877.DSPM POWER  
 1.877.377.6769  
 Fax: 909.930.3335

Represented by: